

**REFERENCE**

SPEC. No. ED-04G026  
ISSUE March 24, 2004

**SHARP**

OPTO-ELECTRONIC DEVICES DIVISION  
ELECTRONIC COMPONENTS GROUP  
SHARP CORPORATION

**SPECIFICATION**

DEVICE SPECIFICATION FOR

PHOTOINTERRUPTER

MODEL No.

GP1A30RJ000F

Specified for

---

Enclosed please find copies of the Specifications which consists of 11 pages including cover.  
After confirmation of the contents, please be sure to send back  copies of the Specifications  
with approving signature on each.

CUSTOMER'S APPROVAL

DATE

---

BY

---

PRESENTED

DATE

---

BY

*27.0*

---

H. Ogura,  
Department General Manager of  
Engineering Dept., III  
Opto-Electronic Devices Div.  
ELECOM Group  
SHARP CORPORATION

**REFERENCE**Product name : PHOTOINTERRUPTERModel No. : GP1A30RJ000F

1. These specification sheets include materials protected under copyright of Sharp Corporation ("Sharp"). Please do not reproduce or cause anyone to reproduce them without Sharp's consent.
2. When using this product, please observe the absolute maximum ratings and the instructions for use outlined in these specification sheets, as well as the precautions mentioned below. Sharp assumes no responsibility for any damage resulting from use of the product which does not comply with the absolute maximum ratings and the instructions included in these specification sheets, and the precautions mentioned below.

**(Precautions)**

- (1) This product is designed for use in the following application areas ;

{	• OA equipment    • Audio visual equipment    • Home appliances
	• Telecommunication equipment (Terminal)    • Measuring equipment
	• Tooling machines    • Computers

If the use of the product in the above application areas is for equipment listed in paragraphs (2) or (3), please be sure to observe the precautions given in those respective paragraphs.

- (2) Appropriate measures, such as fail-safe design and redundant design considering the safety design of the overall system and equipment, should be taken to ensure reliability and safety when this product is used for equipment which demands high reliability and safety in function and precision, such as ;

{	• Transportation control and safety equipment (aircraft, train, automobile etc.)
	• Traffic signals    • Gas leakage sensor breakers    • Rescue and security equipment
	• Other safety equipment    etc.

- (3) Please do not use this product for equipment which require extremely high reliability and safety in function and precision, such as ;

{	• Space equipment    • Telecommunication equipment (for trunk lines)
	• Nuclear power control equipment    • Medical equipment    etc.

- (4) Please contact and consult with a Sharp sales representative if there are any questions regarding interpretation of the above three paragraphs.

3. Please contact and consult with a Sharp sales representative for any questions about this product.

# REFERENCE

## 1. Application

This specification applies to the outline and characteristics of transmissive type photointerrupter, Model No. GP1A30RJ000F.

## 2. Outline

Refer to the attached drawing No. CY12002i02.

## 3. Ratings and characteristics

- Refer to the attached sheet, Page 4 to 7.
- Resolution : Disk slit pitch = 0.704mm
- Output waveform : Digital 2-phase (Phase A and Phase B)

## 4. Reliability

Refer to the attached sheet, Page 8.

## 5. Outgoing inspection

Refer to the attached sheet, Page 9.

## 6. Supplements

### 6.1 Parts

Refer to the attached sheet, Page 10.

### 6.2 ODS materials

This product shall not contain the following materials.

Also, the following materials shall not be used in the production process for this product.

Materials for ODS : CFCs, Halon, Carbon tetrachloride, 1,1,1-Trichloroethane (Methyl chloroform)

### 6.3 Brominated flame retardants

Specific brominated flame retardants such as the PBBO<sub>S</sub> and PBB<sub>S</sub> are not used in this device at all.

### 6.4 Lead content

This product dose not contain lead.

### 6.5 Product mass : Approximately 1.1g

## 7. Notes

7.1 It is recommended that the GP1A30RJ000F be used under the condition of typical  $I_F=30\text{mA}$  for which it is designed.

7.2 In order to stabilize power supply line, connect a by-pass capacitor of more than  $0.01\ \mu\text{F}$  between Vcc and GND near the device.

7.3 Tightening torque of set screw (M2) for mounting the GP1A30RJ000F shall be 6kg-cm (MAX.)

### 7.4 Cleaning conditions :

(1) Solvent cleaning : Solvent temperature 45°C or less

Immersion 3 min. or less

(2) Ultrasonic cleaning : The effect to device by ultrasonic cleaning differs by cleaning bath size, ultrasonic power output, cleaning time, PCB size or device mounting condition etc.

Please test it in actual using condition and confirm that doesn't occur any defect before starting the ultrasonic cleaning.

(3) Applicable solvent : Ethyl alcohol, Methyl alcohol, Isopropyl alcohol

### 7.5 Soldering

To solder onto lead pins, solder at 260°C for 5 seconds or less.

Please take care not to let any external force exert on lead pins when soldering or just after soldering.

Please don't do soldering by reflow.

### 7.6 Disk design for GP1A30RJ000F

Given the disk resolution (N), Ro(distance between the disk center and half of a slit) and S1,S2 (installing position of encoder) will be provided by the following equations.

$$R_o = N / 120 \times 13.45 \text{ (Unit : mm)}$$

$$S_1 = R_o - 1.765 \text{ (Unit : mm)}$$

$$S_2 = S_1 + 6.7 \text{ (Unit : mm)}$$

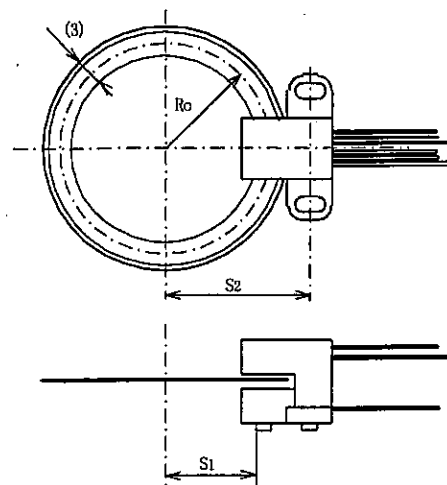

2 Outline (Drawing No. CY12002i02)

Scale : 2/1 Unit : mm

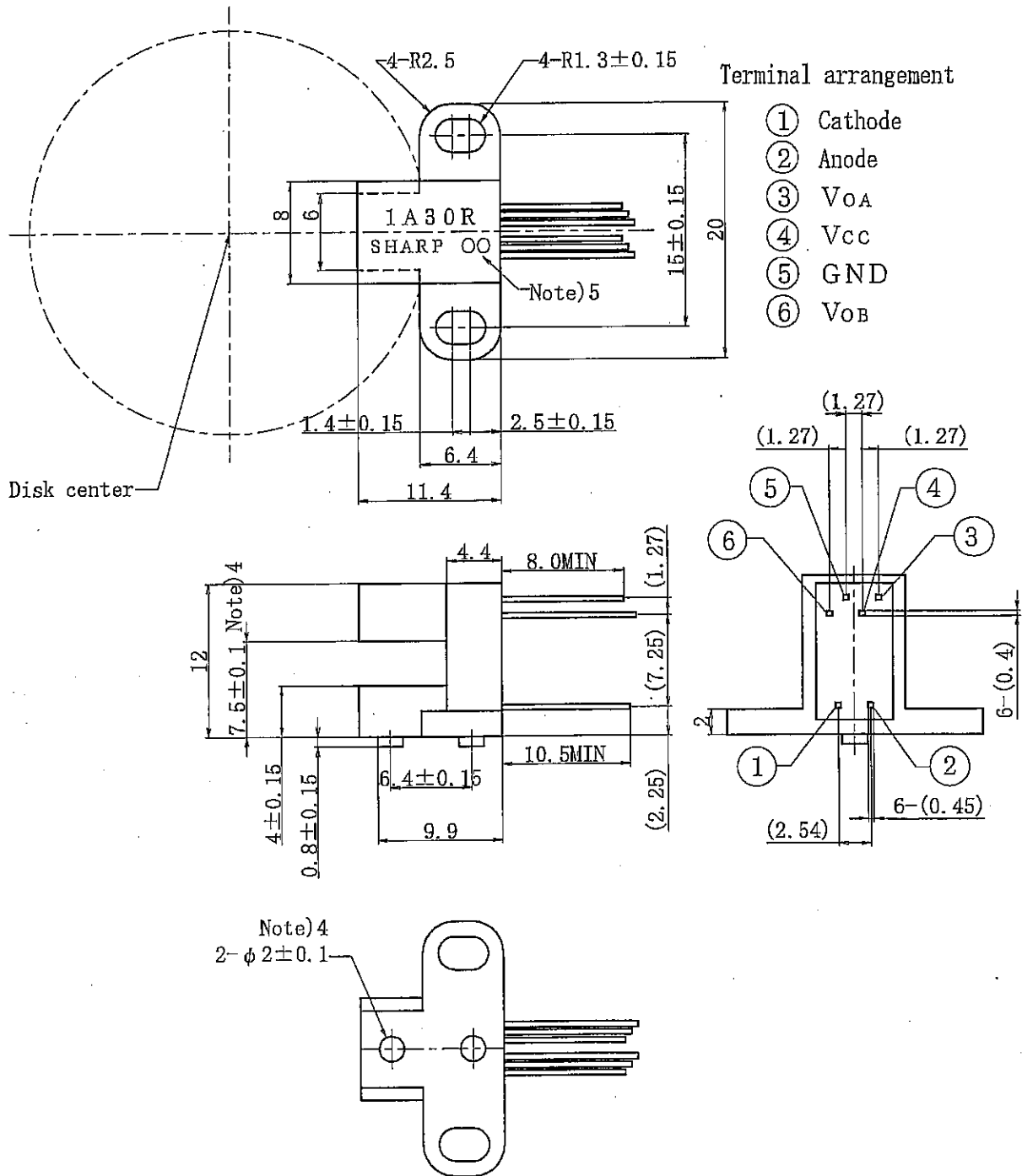

**Note**

- 1) Unspecified tolerances shall be ± 0.3.
- 2) Dimensions in parenthesis are shown for reference.
- 3) The disk is not included in this encoder module, GP1A30RJ000F.
- 4) The outline dimensions which affects electrical characteristics in outgoing inspection standard.
- 5) Date code shall be displayed in 2 digits.

REFERENCE

3. Ratings and characteristics

3.1 GPIA30RJ000F block diagram

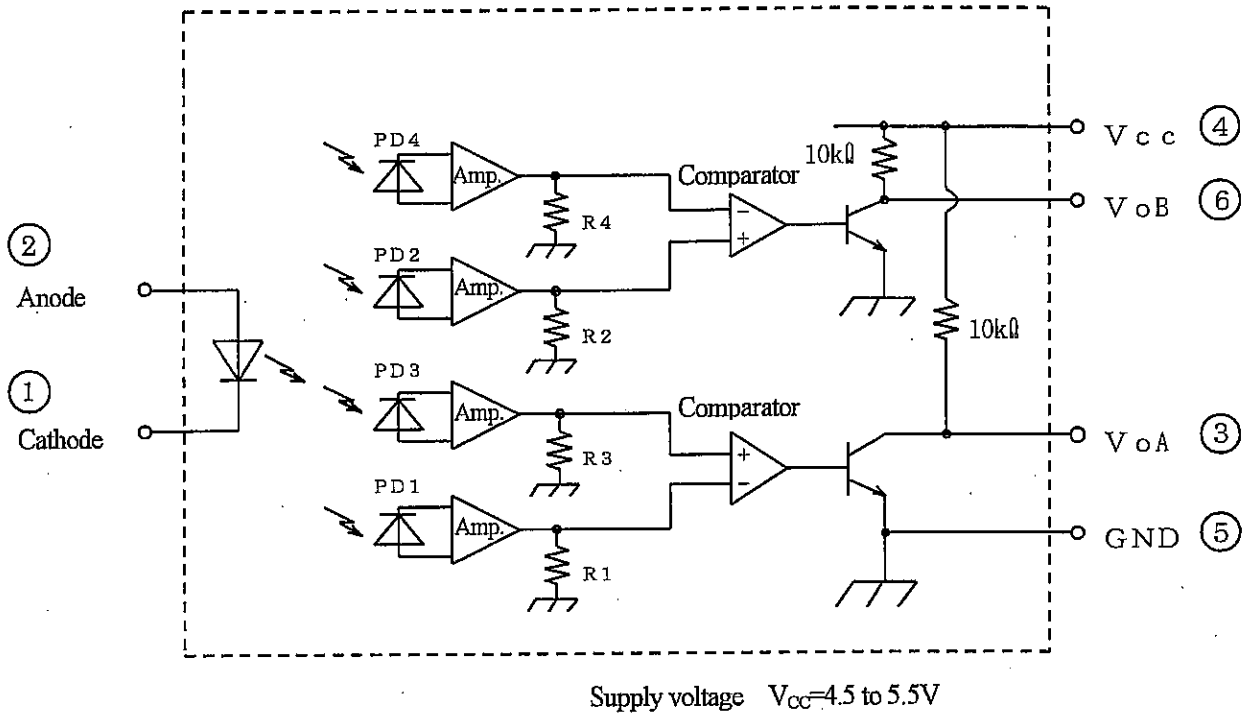

3.2 Absolute maximum ratings

$T_a=25^{\circ}C$

Parameter		Symbol	Rating	Unit
Input	Forward current *2	$I_F$	65	mA
	Peak forward current *1	$I_{FM}$	1	A
	Reverse voltage	$V_R$	6	V
	Power dissipation	P	100	mW
Output	Supply voltage	$V_{CC}$	7	V
	Low level output current	$I_{OL}$	20	mA
	Power dissipation *2	$P_o$	250	mW
Operating temperature		$T_{opr}$	0 to +70	$^{\circ}C$
Storage temperature		$T_{stg}$	-40 to +80	$^{\circ}C$
Soldering temperature *3		$T_{sol}$	260	$^{\circ}C$

\*1 Pulse width  $\leq 100 \mu s$ , Duty ratio = 0.01

\*2 The derating factors of absolute maximum ratings due to ambient temperature are shown in Fig. 1, 2.

\*3 For 5s

# REFERENCE

## 3.3 Electro-optical characteristics

(Unless otherwise specified Ta = 0 ~ 70°C)

Parameter		Symbol	Conditions	MIN.	TYP.	MAX.	Unit
Input	Forward voltage	$V_F$	$I_F=30\text{mA}$ , $T_a=25^\circ\text{C}$	-	1.2	1.5	V
	Reverse current	$I_R$	$V_R=3\text{V}$ , $T_a=25^\circ\text{C}$	-	-	10	$\mu\text{A}$
Output	Operating supply voltage range	$V_{CC}$	-	4.5	5.0	5.5	V
	Low level output voltage	$V_{OL}$	$V_{CC}=5\text{V}$ , $I_F=30\text{mA}$ $I_{OL}=8\text{mA}$	-	0.1	0.4	V
	High level output voltage	$V_{OH}$	$V_{CC}=5\text{V}$ , $I_F=30\text{mA}$	2.4	4.9	-	V
	Supply current	$I_{CC}$	$V_{CC}=5\text{V}$ , $I_F=30\text{mA}$ Phases A and B both at low level	-	5	20	mA
Transfer characteristics ※1	Duty	$D_A$	$V_{CC}=5\text{V}$ $I_F=30\text{mA}$ $f=2.5\text{kHz}$	20	50	80	%
		$D_B$					
	Response frequency	$f_{\text{max}}$		$V_{CC}=5\text{V}$ , $I_F=30\text{mA}$	-	-	5

※1 The test condition is according to Fig.3 (CY12003i06)

Transfer characteristics value does not include any error of disk slit

Note: It is recommended that the GPLA30RJ000F be used under the condition of typical  $I_F=30\text{mA}$  for which it is designed.

## 3.4 Output waveform

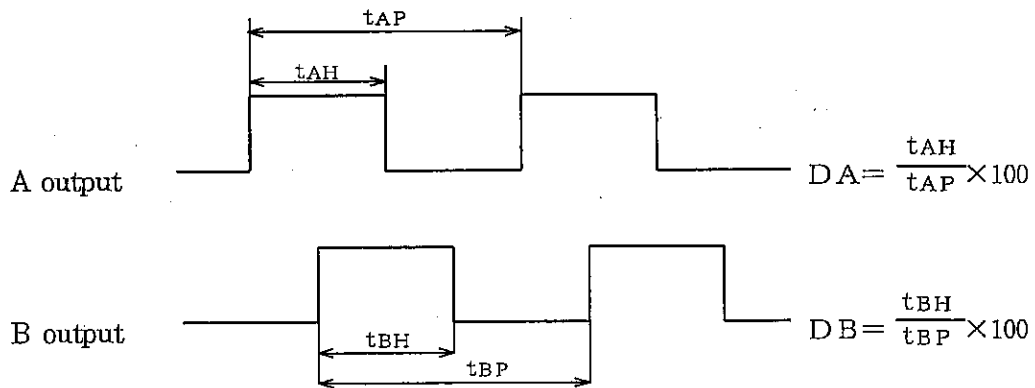

The rotational direction can be distinguished by phase-adjustment of A and B when mounting the encoder.

**REFERENCE**

Fig.1 Forward current vs. ambient temperature

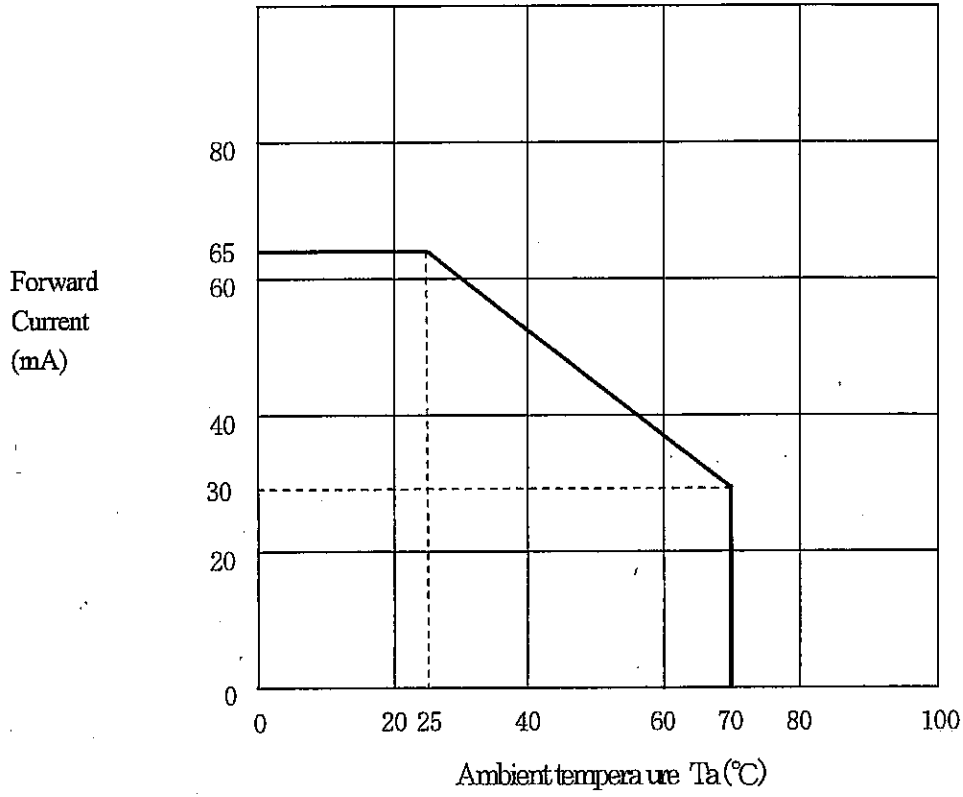
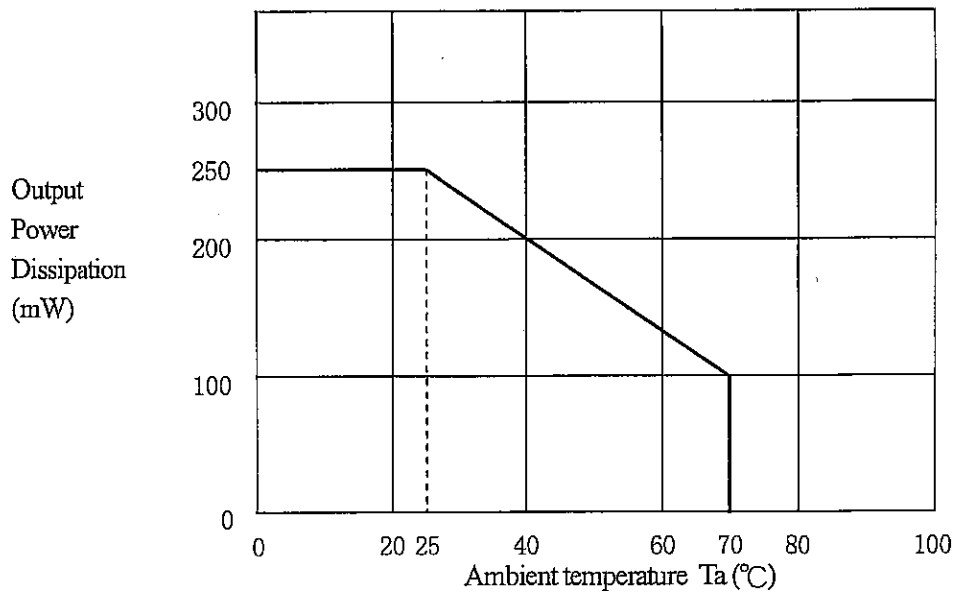

Fig.2 Output power dissipation vs. ambient temperature



# REFERENCE

ED-04G026 GP1A30RJ000F

March 24, 2004

Fig3 GP1A30RJ000F Test Condition (Drawing No.CY12003i06)

Scale : Free Unit : mm

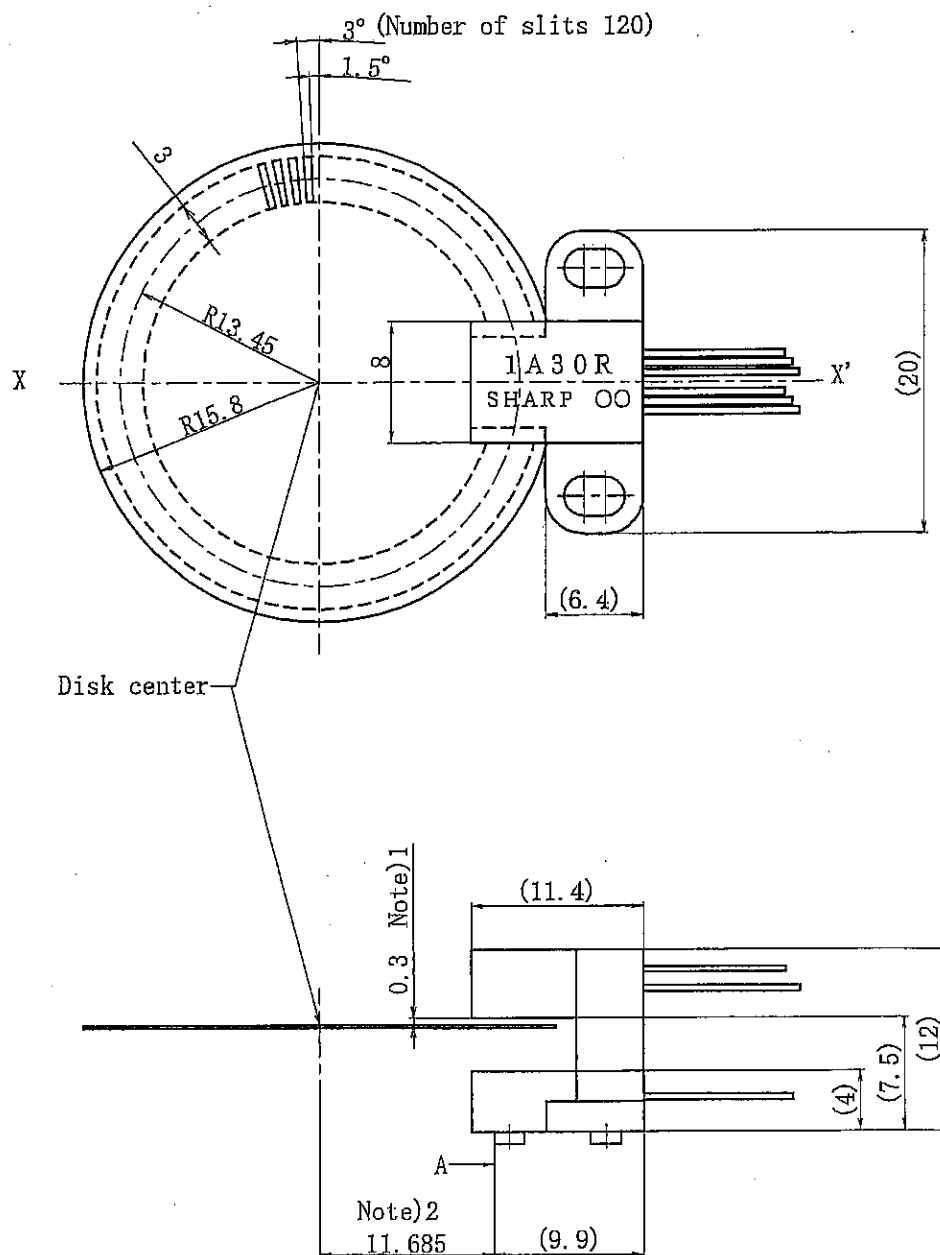

## Note

- 1) Distance between disk surface and case surface in the detector side is 0.3mm.
- 2) Encoder positioning pin is positioned on X-X' axis. Distance between center of disk and portion A of positioning pin is 11.685mm.
- 3) Center of disk slit is R13.45mm.



4. Reliability

The reliability of products shall satisfy items listed below.

Confidence level : 90%

LTPD : 10 or 20

Test Items	Test Conditions	Failure Judgement Criteria	Samples (n)
			Defective (c)
Temperature cycling	1 cycle -40°C to +80°C (30min) (30min) 20 cycles test	$V_F \geq U \times 1.2$	n=22, c=0
High temp. and high humidity storage	+60°C, 90%RH, 500h	$I_R \geq U \times 2$	n=22, c=0
High temp. storage	+80°C, 500h	$V_{OL} \geq U \times 1.2$	n=22, c=0
Low temp. storage	-40°C, 500h	$V_{OH} \leq L \times 0.8$	n=22, c=0
Operation life	$I_F=30mA, V_{CC}=5V, T_a=25^\circ C, 500h$		n=22, c=0
Mechanical shock	15km/s <sup>2</sup> , 0.5ms 3 times/ $\pm X, \pm Y, \pm Z$ direction	$I_{CC} \geq U \times 1.2$	n=11, c=0
Variable frequency vibration	100 to 2000 to 100Hz/4min 4 times/X, Y, Z direction 200m/s <sup>2</sup>	Duty : Shall be within the specification values.	n=11, c=0
Terminal strength (Tension)	Weight: 10N 30s/each terminal		n=11, c=0
Terminal strength (Bending)	Weight: 5N 0° →90° →0° →-90° →0° 1time bending	U: Upper specification limit	n=11, c=0
Soldering heat	260°C, 5s Immerse up to 1.6mm from the side face of package.	L: Lower specification limit	n=11, c=0
Solderability	245±3°C, 5s *2	Judgement only appearance  Solder shall adhere at less than 95% area of immersed portion of lead.	n=11, c=0

\* 1 Test conditions shall be based upon the specification.

\*2 The alloy composition of solder used for lead free should be Sn-3.0Ag-0.5Cu.

Flux used for precleaning should be equivalent to EC-19S(TAMURA KAKEN CORPORATION).

# REFERENCE

## 5. Outgoing inspection

### 5.1 Inspection items

(1) Electrical characteristic

$V_F, I_R, V_{OL}, V_{OH}, I_{CC}, D_A, D_B$

(2) Appearance

### 5.2 Sampling method and Inspection level

A single sampling plan, normal inspection level II based on ISO 2859 is applied.

The AQL according to the inspection items are shown below.

Defect	Inspection item	AQL (%)
Major defect	Characteristics defect	0.10
	Outline dimensions to influence electrical characteristics*	
	Unreadable marking	
Minor defect	Appearance defect except the above mentioned.	0.25

\* Refer to note 4) in the GP1A30RJ000F Outline Dimensions ( Drawing No.CY12002i02 )

## 6. Supplements

### 6.1 Parts

This product uses the below parts.

#### 6.1.1 Light detector (Q'ty : 1)

(Using a silicon photodiode as light detecting portion, and a bipolar IC as signal processing circuit.)

Type	Maximum sensitivity wavelength (nm)	Sensitivity wavelength (nm)	Response time ( $\mu$ s)
Photodiode	900	400 to 1200	200

#### 6.1.2 Light emitter (Q'ty : 1)

Type	Material	Maximum light emitting wavelength (nm)
Infrared light emitting diode (Non-coherent)	Ga As	950

#### 6.1.3 Material

Holder	Lead plating
Black polycarbonate resin	Sn-Ag-Cu

#### 6.1.4 Others

This product shall not be proof against radiation flux.

Laser generator is not used.